

CONCRETE PAD FOUNDATION PAD-MOUNTED TRANSFORMER

750 TO 2500 KVA, THREE-PHASE, 12.5 KV & 34.5 KV HIGH SIDE

CONSULT COMPANY FOR DETAILS BEFORE INSTALLATION.

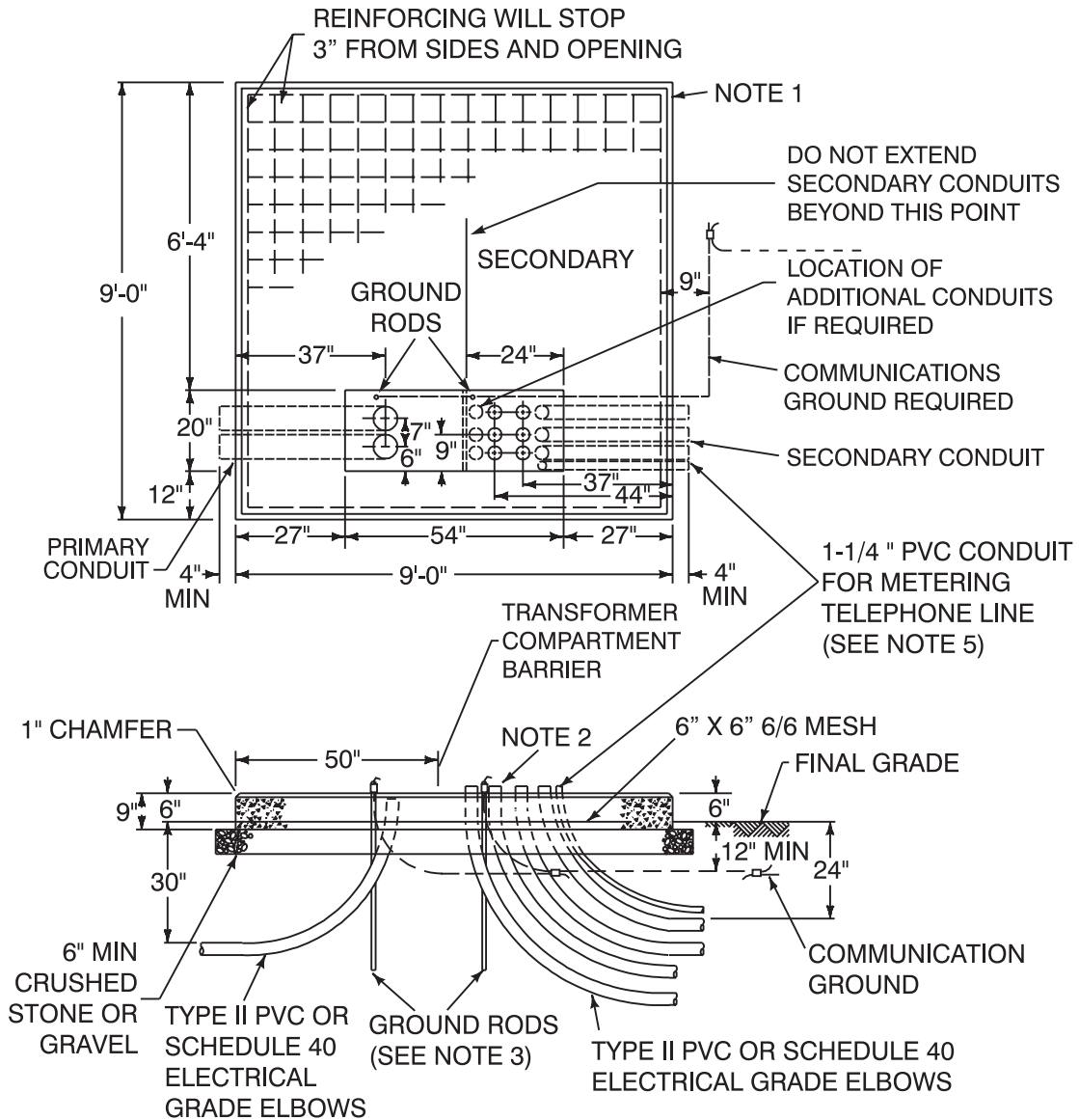

NOTES:

1. CONCRETE SHALL BE 3000 PSI IN ACCORDANCE WITH FIGURE 30. VOLUME OF CONCRETE IS APPROXIMATELY 1.7 CU YDS.
2. SECONDARY CONDUITS SHOULD NOT EXTEND MORE THAN 2" ABOVE TOP OF FOUNDATION. PRIMARY CONDUITS SHOULD BE CUT OFF 2" BELOW THE TOP OF FOUNDATION TO ALLOW FOR TERMINATING CABLES.
3. EXTEND GROUND RODS 2" ABOVE TOP OF FOUNDATION TO ACCOMMODATE GROUND JUMPER.
4. SEE FIGURE 25 FOR CLEARANCE FROM BUILDING WALL OR OTHER PARTS OF BUILDING.
5. EXTEND 1-1/4" CONDUIT TO LOCATION AT CUSTOMER'S BUILDING WHERE TELEPHONE LINE SERVICE CAN BE MADE AVAILABLE AT THE TELEPHONE DEMARCATION POINT (SEE SECTION 8.08).